

# Isomix-F

Control station for constant maintenance of the flow temperature in surface heating systems

**Installation and Operating Manual**  
**(translated from the original operating manual)**



## Contents

<b>1</b>	<b>General information .....</b>	<b>2</b>
1.1	Important information about this manual .....	2
1.2	Product conformity .....	2
1.3	Product features .....	2
<b>2</b>	<b>Safety .....</b>	<b>3</b>
2.1	Presentation of safety information.....	3
2.2	Important safety information .....	3
2.3	Intended use.....	3
2.4	Foreseeable misuse.....	3
2.5	Responsibilities of the plant operator.....	3
2.6	Personnel groups .....	3
2.7	Information on the operating environment .....	3
<b>3</b>	<b>Structure.....</b>	<b>4</b>
<b>4</b>	<b>Function .....</b>	<b>4</b>
<b>5</b>	<b>Technical data.....</b>	<b>4</b>
<b>6</b>	<b>Overall dimensions.....</b>	<b>5</b>
<b>7</b>	<b>Pressure loss diagram .....</b>	<b>5</b>
<b>8</b>	<b>Installation and commissioning.....</b>	<b>6</b>
8.1	Installation.....	6
8.2	Mounting in combination with Heat Interface Unit HIU 2 ..	6
8.3	Temperature limiter .....	7
8.4	Initial commissioning.....	7
8.5	Setting the floor flow temperature .....	7
8.6	Limiting the floor flow temperature .....	7
<b>9</b>	<b>Troubleshooting.....</b>	<b>8</b>
<b>10</b>	<b>Maintenance.....</b>	<b>9</b>
10.1	Annual maintenance .....	9
10.2	Replacement of wear parts .....	9
<b>11</b>	<b>Disposal .....</b>	<b>10</b>
11.1	Return to the manufacturer.....	10
11.2	Notification of administrative bodies and the manufacturer ..	10
<b>12</b>	<b>Warranty .....</b>	<b>10</b>

## 1 General information

### 1.1 Important information about this manual

**NOTICE** The plant operator is responsible for ensuring compliance with the local laws and regulations (e.g. accident prevention regulations, etc.). Incorrect operation or operating the Isomix-F outside the specifications invalidates all warranty claims.

This installation and operating manual

- is an integral part of the Isomix-F
- contains instructions and information about safe and correct installation and commissioning of the Isomix
- must be available to all users throughout the entire service life of the Isomix
- is intended for trained personnel who are familiar with the applicable standards and regulations and, in particular, with the relevant safety concepts, operation and maintenance of the Isomix
- is protected by copyright and may not be altered without the manufacturer's permission

### 1.2 Product conformity

A Declaration of Conformity according to Machinery Directive 2006/42/EC has been issued for the Isomix-F product.

### 1.3 Product features

- All connections to the system have 1" male thread and flat sealing
- Very convenient controls, compact, space-saving design.

## 2 Safety

### 2.1 Presentation of safety information

**⚠ DANGER** DANGER indicates an imminent danger that may cause serious physical injury or death if the appropriate safety precautions are not in place.

**⚠ WARNING** WARNING indicates a danger arising through incorrect behavior (e.g. misuse, disregarding notices, etc.) that may cause serious physical injury or death.

**⚠ CAUTION** CAUTION indicates a potentially dangerous situation that may cause minor or slight injuries if the appropriate safety precautions are not in place.

**NOTICE** NOTE indicates a situation that may cause material damage if the corresponding precautions are not taken.

### 2.2 Important safety information

- Before using the Isomix-F, read this operating manual through carefully.
- Connect the Isomix-F only to a power source that corresponds to the mains voltage specified on the rating plate of the Isomix-F.
- The power supply to the Isomix-F must be disconnected prior to maintenance, cleaning and repair work.
- Maintenance, cleaning and repair work may be carried out by trained specialist personnel only.
- The Isomix-F must not be used if it is damaged or is no longer operating correctly. In this case, contact your specialist dealer immediately.
- Observe the maintenance instructions and intervals.
- Protect the Isomix-F from the weather.
- Never use the Isomix-F outdoors.
- The unit may be used only in accordance with its intended use.

### 2.3 Intended use

The control station Isomix-F is used for constant maintenance of the flow temperature in surface heating systems. The control station is intended for use in dry rooms in residential or commercial areas. It is usually installed in the heating room or in a distribution cabinet.

The Isomix-F is not intended to be operated by people (including children) with limited physical, sensory or mental capacities, or by people with insufficient experience or previous knowledge.

### 2.4 Foreseeable misuse

The following is considered to be foreseeable misuse:

- Operating the Isomix-F beyond its specifications.
- Improper use of the Isomix-F.
- Modifications to the Isomix-F that have not been agreed with the manufacturer.
- Use of replacement or wear parts that have not been approved by the manufacturer.
- Operating the Isomix-F outdoors.

### 2.5 Responsibilities of the plant operator

The plant operator must ensure that:

- the Isomix-F is used only for its intended purpose
- the Isomix-F is installed, operated and maintained according to the specifications of the installation and operating manual
- the Isomix-F is operated only in accordance with local regulations and occupational health and safety regulations
- all precautionary measures have been taken to avoid dangers originating from the Isomix-F
- all precautions for first aid and firefighting have been taken
- only authorized and trained users have access to the Isomix-F and operate it
- users have access to this installation and operating manual at all times

### 2.6 Personnel groups

Only qualified persons may install and operate the Isomix-F and carry out maintenance work.

#### Operators

Operators are deemed to be qualified if they have read these operating instructions and understood the potential hazards associated with improper behavior.

#### Fitters/commissioning engineers

Fitters/commissioning engineers are in a position to carry out work on the Isomix-F, taking into consideration the applicable standards, provisions, regulations and laws and their technical training and technical knowledge, and can detect and prevent potential hazards.

### 2.7 Information on the operating environment

Corrosion and chemical and physical reactions can damage the control station.

**The system planner is responsible for evaluating these parameters and developing remedies.**

### 3 Structure

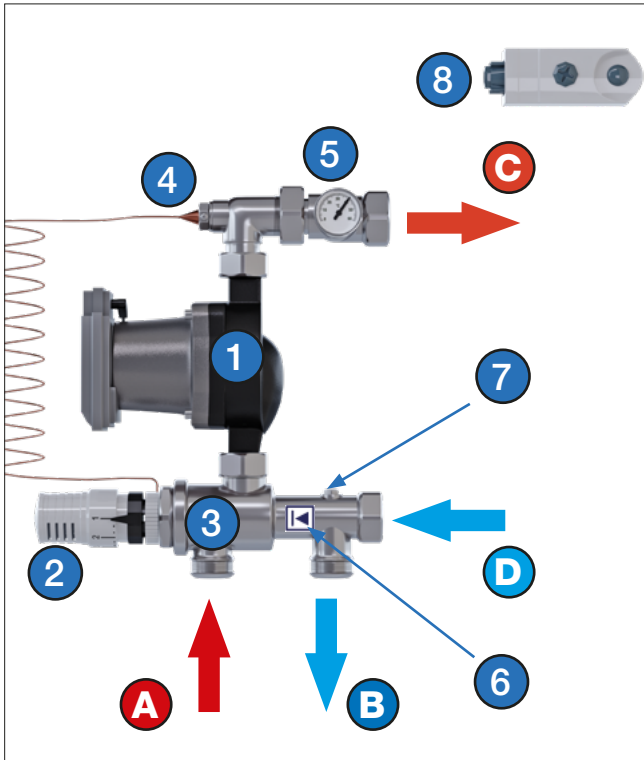

Fig. 3-1 Structure

- 1 Circulation pump
- 2 Thermostatic head
- 3 3-way mixer valve
- 4 Thermowell for capillary tube temperature sensor
- 5 Eccentric screw fitting with thermometer
- 6 Insert check valve
- 7 Connection for return flow sensor 1/8"(option)
- 8 Temperature limiter (optional)
- A Primary supply (1" male thread)
- B Primary return (1" male thread)
- C Surface heating/cooling supply (1" union nut)
- D Surface heating/cooling return (1" union nut)

### 4 Function

The mixer valve (3) on the control station is controlled via a thermostat head (2) with capillary tube and sensor element on the heating circuit supply (A). Deviations from the set value immediately cause a valve stroke change, thereby changing the quantity of hot water injected from the boiler circuit accordingly. The water injected mixes with the return water from the heating circuit and thus keeps the flow temperature constant within a narrow range. The actual value can be checked on the thermometer (5). Check valve (6) prevents a short-circuit of the primary circuit

The temperature limiter (8) switches off the circulating pump (1), when the supply temperature is exceeded, thus preventing the panel heating system from overheating.

### 5 Technical data

Hydraulic performance data	
Max. operating pressure	10 bar
Max. ambient temperature	40 °C
Max. operating temperature	80 °C
Setting range of supply temperature	20 - 70 °C
Kvs value	3,2 m³/h
Heating demand	14 kW at ΔT=10K
Differential pressure	max. 500 mbar
Media	Water/water-glycol mixture as per VDI 2035/ÖNORM (Austrian standard) 5195
Connections to pipe network	
Primary (heat generator)	1" male thread, flat sealing
Secondary (heat distribution)	1" fl. (union nut), flat sealing
Toques of the fitting	
¾"	35 Nm
1"	55 Nm
Materials	
Fittings	Brass CW617 N, nickel plated
Seals and O-rings	AFM34/2 and EPDM
Plastics	Impact resistant and temperature resistant
Circulation pump and temperature limiter	
Technical data can be found in the enclosed technical documentation.	

## 6 Overall dimensions

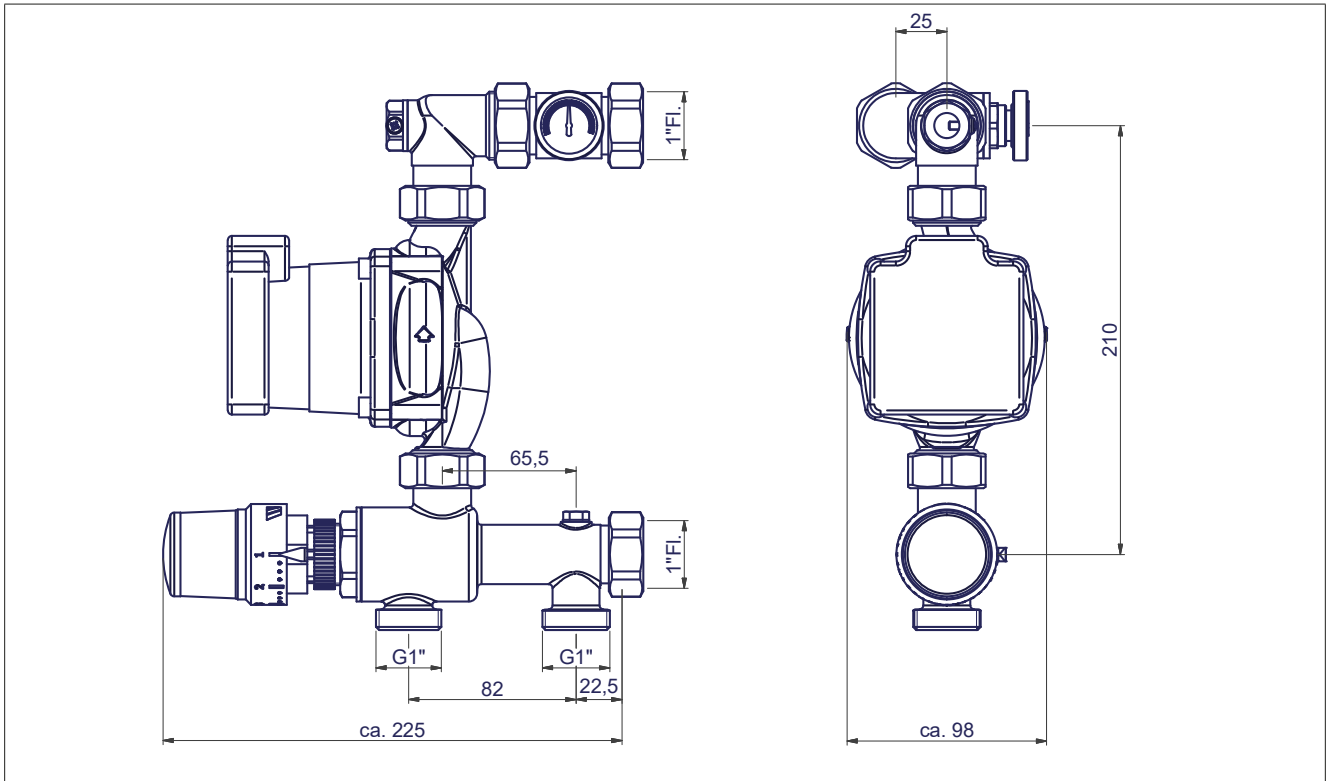

Fig. 6-1 Overall dimension

## 7 Pressure loss diagram

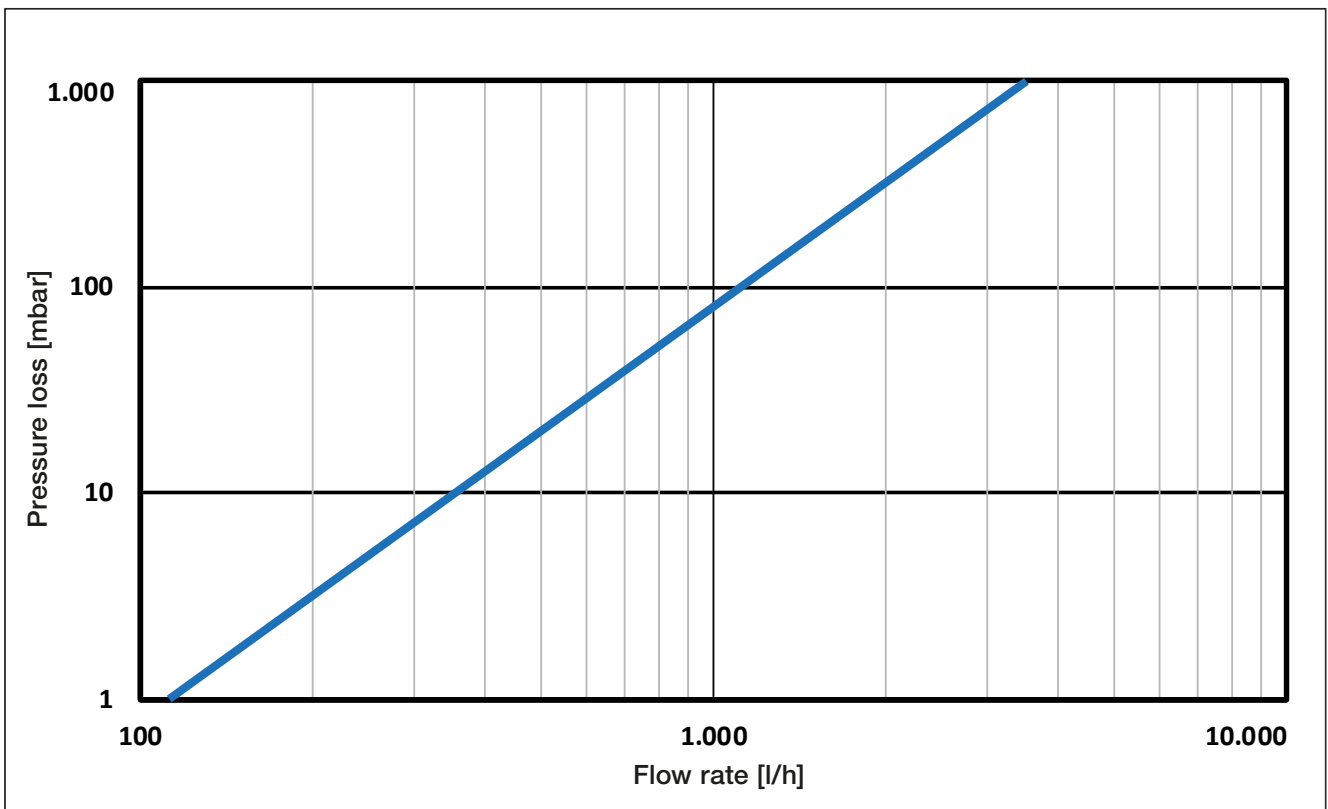

Fig. 7-1 Pressure loss diagram

## 8 Installation and commissioning

**⚠ DANGER** Electrical energy!  
Risk of death from electric shock.

- Work on parts carrying live voltage must be carried out by qualified electricians only.
- Disconnect the power supply of the system and secure it to prevent it from being switched on again before carrying out any installation, maintenance, cleaning or repair work.

**NOTICE** The installation and commissioning of the Isomix-F must be carried out only by trained personnel who have been authorized by the manufacturer.

**⚠ CAUTION** When repairing the unit or replacing parts, be sure to observe the specified installation positions and flow directions of the parts being replaced!

**⚠ CAUTION** Material damage!  
Pressure shocks may occur if the stop valve is opened or closed quickly.

- Always open and close the stop valves slowly and in a controlled way.

### 8.1 Installation

All screw fittings must be checked and tightened if necessary prior to installation and commissioning! For the torques of the fitting see „5 Technical data“ page 4.

**⚠ WARNING** Hot water!  
Risk of severe scalding.

Do not reach into the hot water when emptying the Isomix-F. Ensure that the Isomix-F has cooled down before carrying out maintenance, cleaning and repair work.

During installation it must be ensured that:

- the cables from the pump and temperature limiter are not damaged or kinked
- the sensor capillary tube is not damaged or kinked
- The cables must not be under tension.

1. Fit the control station to the manifold with the 1" nuts and associated seals.

The control station can be fitted on the right or left of the manifold by turning the eccentric screw fitting (5, Fig. 8-1), also upside down.

2. Fit the temperature limiter to the supply collector pipe on the manifold.
3. Connect the control station to the power supply.

Further information about electrical connection of the control station can be found in the separate documentation for the assemblies.

4. Set the temperature on the (optional) temperature limiter to approx. 55 °C.

**NOTICE** To ensure that the pump runs only when heat is required, the manufacturer recommends connecting the pump to a pump relay (e.g. the pump logic of an electrical control distributor that also controls the actuators). Alternatively, the pump can be operated with a timer switch.

### 8.2 Mounting in combination with Heat Interface Unit HIU 2

For use in combination with the Watts HIU 2 Heat Interface Unit, the Isomix-F must be converted (overhead) and the eccentric rotated.

1. Release nut (A, Fig. 8-1)
2. Rotate eccentric (5, Fig. 8-2)
3. Position the temperature limiter (8, Fig. 8-2)

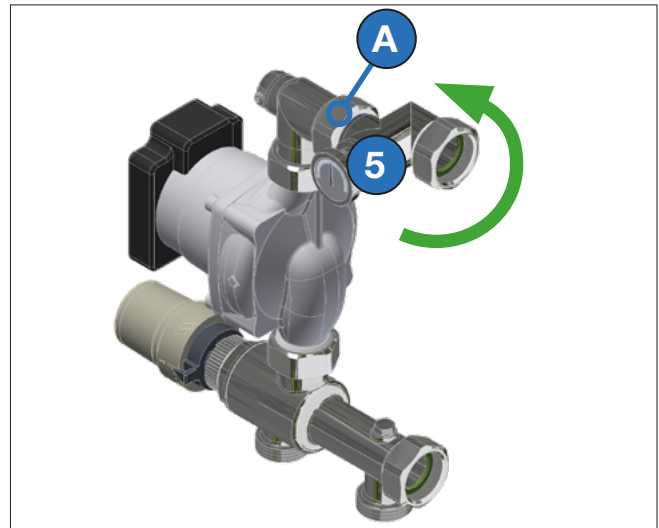

Fig. 8-1

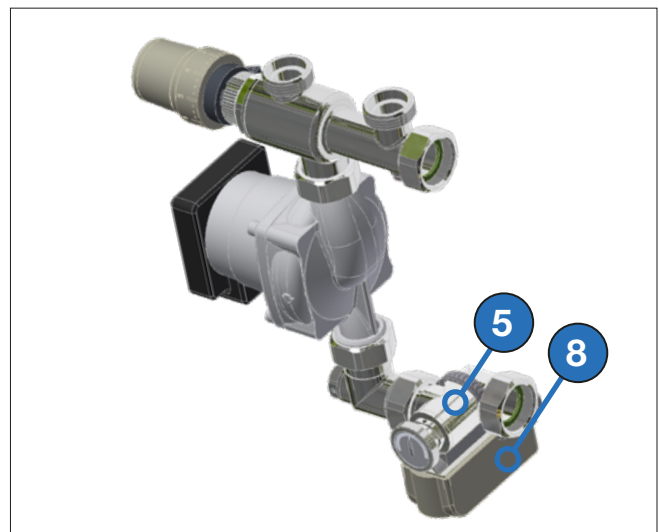

Fig. 8-2

### 8.3 Temperature limiter

In the event of a fault, the temperature limiter switches off the circulation pump and so avoids overheating of the surface heating system.

- The temperature limiter must be fitted to the supply of the heating circuit manifold.
- Set the temperature on the (optional) temperature limiter to approx. 55 °C.

### 8.4 Initial commissioning

1. Connect the control station to the pipe network.
2. Shut off the ball valves (15).
3. Switch off the pump and close all of the heating circuits on the distributor.

It is sufficient to close the valves in the return of the heating circuit manifold with the protection caps.

4. Fill the manifold and control station with hot water (in accordance with VDI 2035):
5. connect the filling hose to the fill and drain valve on the return (9b, Fig. 8-3) and the draining hose to the fill and drain valve on the supply (9a, Fig. 8-3).

Heating circuits are closed.

6. Open both fill and drain valves and fill the manifold and control station until water comes out of the fill and drain valve on the supply. Close both fill and drain valves.
7. To fill and flush the heating circuits, connect the filling hose to the supply fill and drain valve (9a, Fig. 8-4) and the emptying hose to the return fill and drain valve (9, Fig. 8-4).
8. Open the heating circuit to be flushed.
9. Open fill and drain valve and flush out the heating circuit in the direction of flow until the air and any contamination has been removed from the circuit completely.

The non-return valve (14) in the mixer bypass prevents any short circuit when flushing.

10. Repeat the process for all the heating circuits.

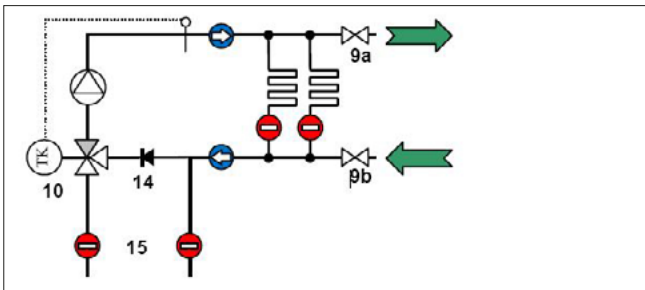

Fig. 8-3

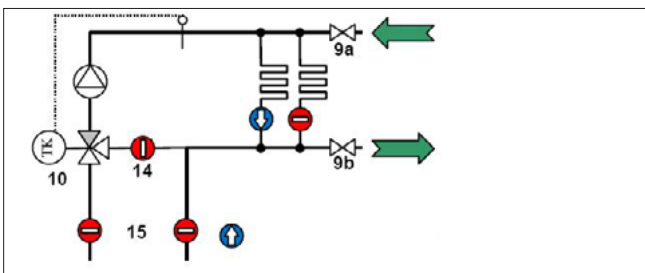

Fig. 8-4

**NOTICE** Flushing is permitted only in the direction of flow of the heating circuits, i.e. the water must enter through the flow manifold and come out of the return! The drain must always be open, as otherwise the high water pressure could damage the heating system. The instructions on flushing in the operating manual for the heating circuit manifold must also be observed.

### 8.5 Setting the floor flow temperature

The adjustment handwheel on the thermostat head has a scale of 1 - 7 (A, Fig. 8-5 Setting of the supply temperature). The set temperature should be taken from the table:

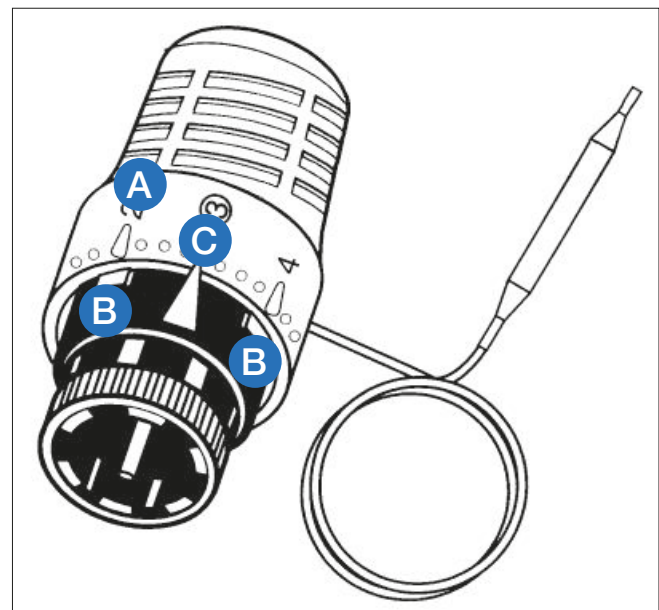

Fig. 8-5 Setting of the supply temperature

1	2	3	4	5	6	7
20 °C	28 °C	37 °C	45 °C	53 °C	62 °C	70 °C

### 8.6 Limiting the floor flow temperature

Flow temperatures above 50 °C are not usually used for surface heating systems.

The system temperature is often significantly lower than the maximum value that can be set on the thermostat head. To avoid damage to the floor structure from excess temperature, the flow temperature set value can be limited and locked in on the thermostat head.

1. Set the temperature and, with the surface heating running, check it on the thermometer.
2. If it is correct, position one of the locking devices (B) directly in front of and behind the marking arrow (C).

The setting can also be protected by an additional adjustment lock (accessory: SE 148 GA) to prevent unintended actuation.

## 9 Troubleshooting

Fault		
	Possible cause	Remedy
<b>1</b>	<b>Underfloor heating circuits do not heat up; pump not running</b>	
1.1	<p>Temperature limiter (TL) is switching the control station pump off.</p> <p>Reason: TL setting is too low.</p>	<p>Set TL to approx. 10 K higher than the underfloor heating flow temperature.</p> <p>Note the maximum permitted temperature for the underfloor heating!</p> <p>The switching difference of the TL is approx. 5 K.</p> <p>The control station is ready to operate more quickly if the TL is removed briefly to cool down to its switching temperature.</p>
1.2	<p>TL is switching the control station pump off.</p> <p>Reason: The pump remains switched on despite closed underfloor heating circuits. The water inside the control station is being heated by waste heat from the pump. The TL switches the pump off when the maximum temperature is reached!</p>	<p>Remove TL from the control station and fit to supply heating circuit manifold.</p> <p>Use electrical control distributor with pump logic (relay). The pump logic ensures that the pump runs only if at least one underfloor heating circuit is open.</p>
1.3	<p>The pump is connected to a room thermostat or electrical control distributor.</p> <p>If all actuators are closed, the pump switches off. During a lengthy shutdown, the underfloor heating flow cools down. The controller therefore causes the 3-way mixer valve to open. Hot water is injected from the primary heating circuit. As a result, the control station heats up. When the maximum temperature of the TL is reached, the contact opens. The pump does not switch on again.</p>	<p>Remove TL from the control station and fit to supply heating circuit manifold.</p> <p>See 1.1</p>
<b>2</b>	<b>Underfloor heating flow temperature cannot be set to the required value or the feed temperature fluctuates significantly</b>	
2.1	Supply and return on the control station have been mixed up	Check that all connections on the control station are correct (see Section "Structure" on page <?>)
2.2	The head / pumping level of the pump is set too low	Change the pump setting (see separate pump instruction manual).
2.3	The differential pressure of the primary pump is too high (>500mbar)	Change the pump setting (see separate pump instruction manual) or fit differential pressure controller.
2.4	The heating load is too high for the control station, i.e. heat consumption exceeds the nominal output of the control station. This condition can come about temporarily, for example, when heating up a "cold" floor.	<p>Establish maximum heat requirement and compare with nominal output. The heating circuits may have to be shared with a second control station with a corresponding heating circuit distributor.</p> <p>If this is caused by heating up the underfloor heating for the first time, it may start working normally after the heating up phase (2 – 3 days). This is particularly likely in the case of operation at the upper nominal output limit.</p>
2.5	The thermostat head is defective.	Replace the thermostat head.



## 10 Maintenance

### **⚠ DANGER** Electrical energy!

Perform maintenance work on the Isomix-F only when the power supply has been disconnected.

### **⚠ WARNING** Hot water!

Risk of severe scalding.

Do not reach into the hot water when emptying the Isomix-F. Ensure that the Isomix-F has cooled down before carrying out maintenance, cleaning and repair work.

### **⚠ WARNING** Hot surfaces!

Risk of serious burns.

Do not touch the pipes or components during operation. Ensure that the Isomix-F has cooled down before carrying out maintenance, cleaning and repair work. Wear heat-resistant safety gloves if it is necessary to carry out work on hot components.

**NOTICE** Maintenance of the Isomix-F must be carried out only by trained personnel who have been authorized by the manufacturer.

## 10.1 Annual maintenance

### 1. General visual inspection

- Check the control station for leaks and retighten sealing connections or replace seals, as required.

### 2. Functional check

- Check that settings and operating and performance parameters are set correctly.
- Check flow noise during operation.
- Ask users if there are any noticeable problems.

### 3. Action to be taken following maintenance work

- Check that all screw fittings that were unscrewed have been retightened and retighten if necessary.
- Remove all tools, materials and other equipment used from the working area.
- Restore the power supply.
- Slowly pressurize the Isomix-F and vent it.
- Readjust the system settings if required.

## 10.2 Replacement of wear parts

Please note that the Isomix-F contains parts that, for technical reasons, are subject to wear depending on the intensity of use, even if the specified care and maintenance has been provided.

This applies especially to mechanical parts and parts that come into contact with water and steam, such as seals, valves, etc.

By their nature, defects caused by wear do not constitute a fault and are therefore not covered by the warranty or any guarantee. Nevertheless, these defects and malfunctions must be remedied by trained specialist personnel only. Contact your specialist dealer for this.

## 11 Disposal



**Potential for contamination of the environment and groundwater from improper disposal!**

**The legal regulations and guidelines in the country of operation must be observed when disposing of components and operating materials.**

1. Ensure that all assemblies and components are de-energized.
2. Disassemble the Isomix-F properly or commission a specialist company to do so.
3. Sort the assemblies and component parts into recyclable materials, hazardous substances and operating materials.
4. Dispose of the assemblies and components in accordance with local laws and regulations or take them to be recycled.

### 11.1 Return to the manufacturer

Get in contact with the manufacturer if you would like to return the Isomix-F or parts of it.

### 11.2 Notification of administrative bodies and the manufacturer

Inform the manufacturer of decommissioning and disposal of the Isomix-F for statistical purposes.

## 12 Warranty

WATTS products are tested extensively. WATTS therefore guarantees only to replace or repair components of the products supplied free of charge – at the sole discretion of WATTS – if, in the opinion of WATTS, they exhibit verifiable manufacturing faults. Warranty claims due to defects or defects of title may be asserted within one (1) year of delivery/transfer of risk. Excluded from the warranty is damage attributable to normal product use or friction and to damage resulting from modifications or unauthorized repairs to the products, for which WATTS rejects all claims for compensation (direct or indirect). (For more detailed information, please refer to our website.) In all cases, supply is subject to the General Terms and Conditions, which can be found on [www.wattswater.eu/gtc/](http://www.wattswater.eu/gtc/).

---

The descriptions and photographs contained in this product specification sheet are supplied by way of information only and are not binding.

Watts Industries reserves the right to carry out any technical and design improvements to its products without prior notice. Warranty: All sales and contracts for sale are expressly conditioned on the buyer's assent to Watts terms and conditions found on its website at [www.wattswater.eu/gtc/](http://www.wattswater.eu/gtc/). Watts hereby objects to any term, different from or additional to Watts terms, contained in any buyer communication in any form, unless agreed to in a writing signed by an officer of Watts.

---



**Watts Industries Deutschland GmbH**

Godramsteiner Hauptstr. 167 • 76829 Landau • Deutschland  
Tel. +49 6341 9656 0 • Fax +49 6341 9656 560  
[WIDE@wattswater.com](mailto:WIDE@wattswater.com) • [www.wattswater.eu](http://www.wattswater.eu)